



US007514280B2

(12) **United States Patent**
Lee

(10) **Patent No.:** **US 7,514,280 B2**
(45) **Date of Patent:** ***Apr. 7, 2009**

(54) **METHOD FOR PACKAGING ORGANIC LIGHT EMITTING DISPLAY WITH FRIT SEAL AND REINFORCING STRUCTURE**

6,998,776 B2 2/2006 Aitken et al.
7,255,823 B1* 8/2007 Guenther et al. 264/263

(75) Inventor: **Jae Sun Lee**, Yongin-si (KR)

(73) Assignee: **Samsung SDI Co., Ltd.** (KR)

(*) Notice: Subject to any disclaimer, the term of this patent is extended or adjusted under 35 U.S.C. 154(b) by 43 days.

This patent is subject to a terminal disclaimer.

(Continued)

FOREIGN PATENT DOCUMENTS

JP 09-278483 10/1997

(Continued)

OTHER PUBLICATIONS

(21) Appl. No.: **11/540,084**

(22) Filed: **Sep. 29, 2006**

(65) **Prior Publication Data**

US 2007/0196949 A1 Aug. 23, 2007

(30) **Foreign Application Priority Data**

Feb. 21, 2006 (KR) 10-2006-0016856

(51) **Int. Cl.**

H01L 51/56 (2006.01)
H01L 21/782 (2006.01)

(52) **U.S. Cl.** **438/28**; 438/33; 438/34;
438/99; 438/458; 257/40

(58) **Field of Classification Search** 438/26,
438/28, 82, 67, 114, 115, 116, 99, 458, 33,
438/34; 257/40

See application file for complete search history.

(56) **References Cited**

U.S. PATENT DOCUMENTS

4,238,704 A 12/1980 Bonk et al.
5,965,907 A 10/1999 Huang et al.
6,555,025 B1 4/2003 Krupetsky et al.
6,650,392 B2* 11/2003 Iwanaga et al. 349/153
6,791,660 B1* 9/2004 Hayashi et al. 349/190

Search Report from the corresponding European Patent Application No. 07101295.9 dated May 24, 2007.

Primary Examiner—David Vu

Assistant Examiner—Earl N Taylor

(74) *Attorney, Agent, or Firm*—Knobbe Martens Olson & Bear LLP

(57) **ABSTRACT**

Disclosed is a method for packaging an organic light emitting display having a reinforcing member between a first substrate and a second substrate by rolling a roll retaining a curable material on non-pixel regions of unit display panels. Organic light emitting pixel arrays are formed at a plurality of pixel regions of a first mother substrate. A frit is formed at a position of a second mother substrate corresponding to the non-pixel regions of the first mother substrate. The mother substrates are coalesced to each other and sealed by the frit. The first and second mother substrates are cut into unit display panels. The unit display panels are aligned. The curable material is coated at a side the unit display panels and cured to form the reinforcing member.

26 Claims, 9 Drawing Sheets

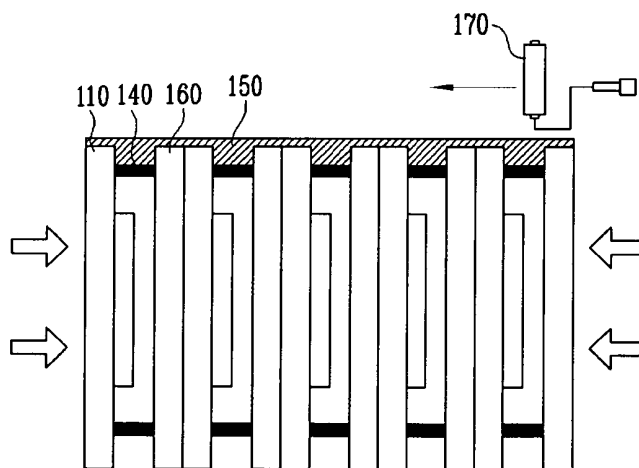

U.S. PATENT DOCUMENTS

2003/0066311	A1 *	4/2003	Li et al.	65/43
2003/0122476	A1	7/2003	Wang et al.	
2003/0218422	A1 *	11/2003	Park et al.	313/512
2004/0069017	A1	4/2004	Li et al.	
2004/0217703	A1 *	11/2004	Wittmann et al.	313/512
2005/0200798	A1 *	9/2005	Tanaka	349/155
2005/0233885	A1	10/2005	Yoshida et al.	

2007/0120478	A1 *	5/2007	Lee et al.	313/512
2007/0172971	A1 *	7/2007	Boroson	438/26

FOREIGN PATENT DOCUMENTS

JP	10-074583	3/1998
WO	02/21557 A1	3/2002

* cited by examiner

FIG. 1A

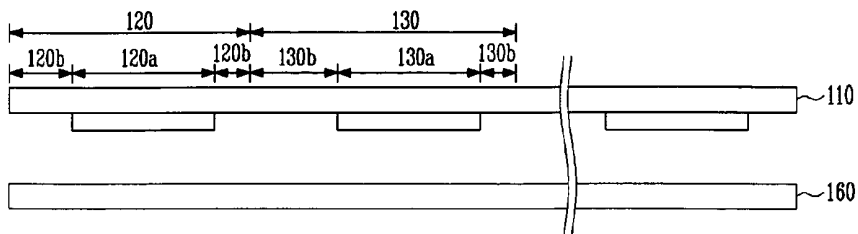

FIG. 1B

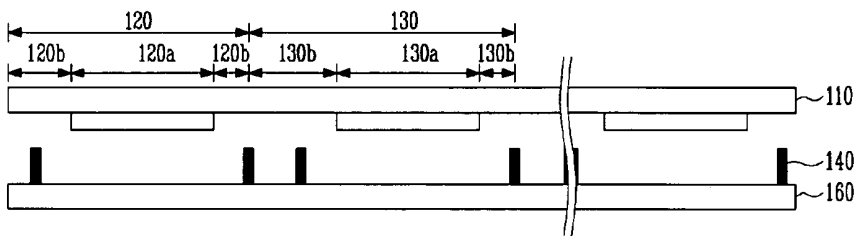

FIG. 1C

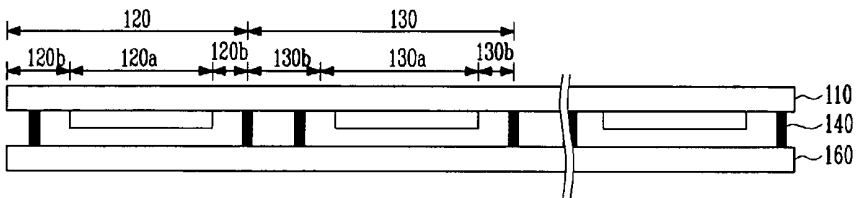

FIG. 1D

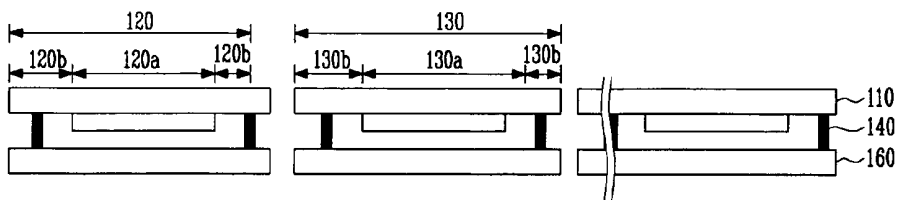

FIG. 1E

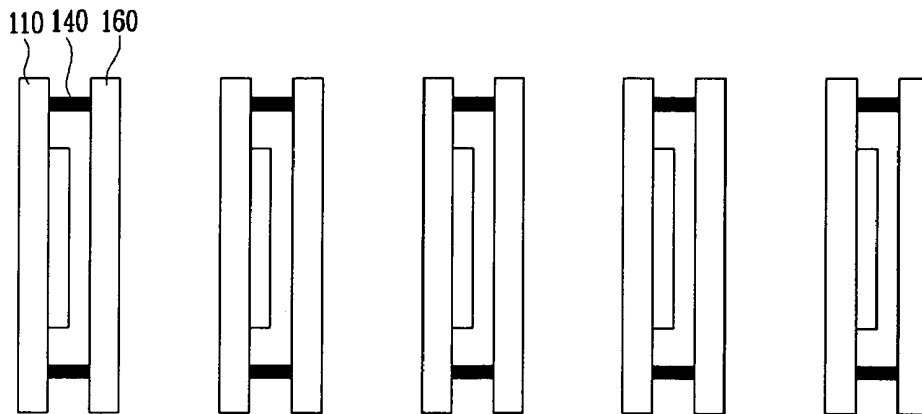

FIG. 1F

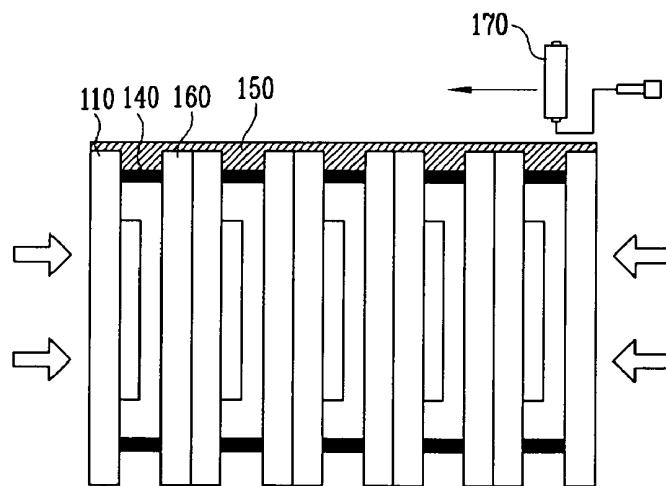

FIG. 1G

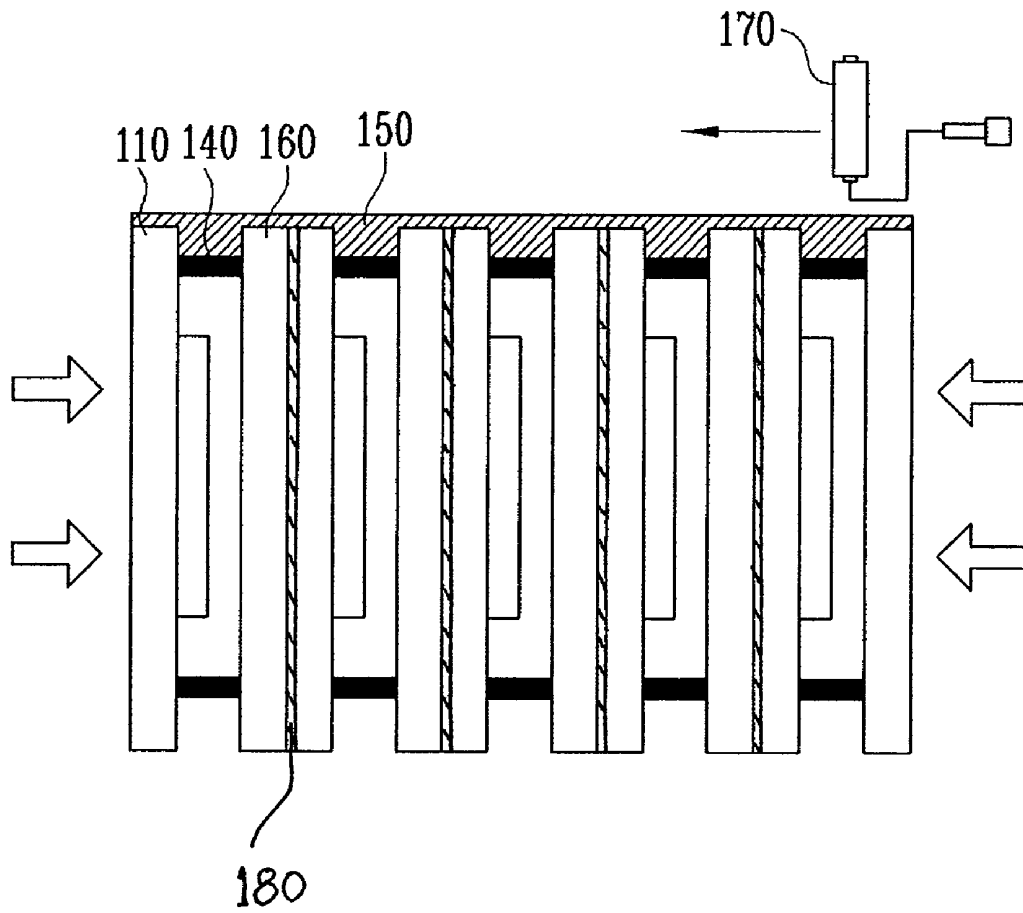

FIG. 2A

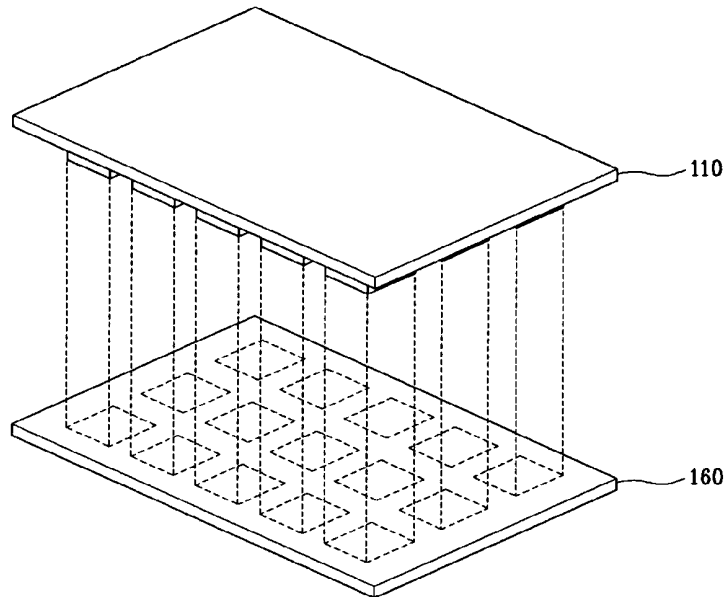

FIG. 2B

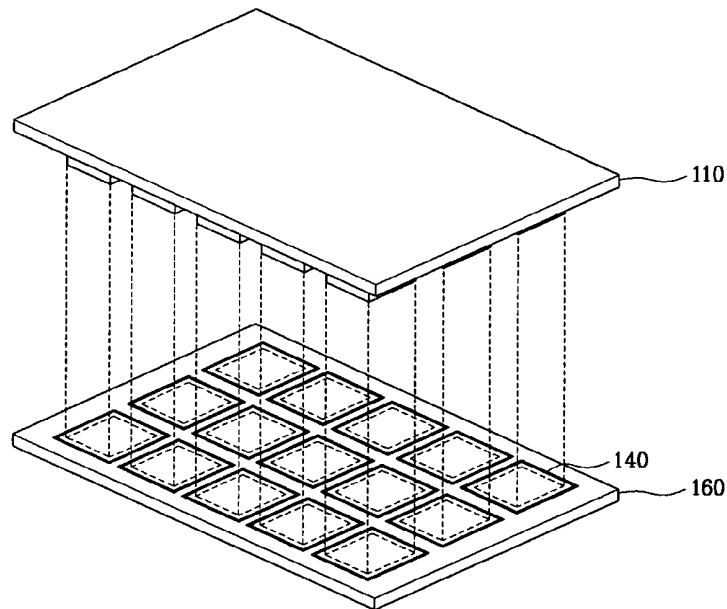

FIG. 2C

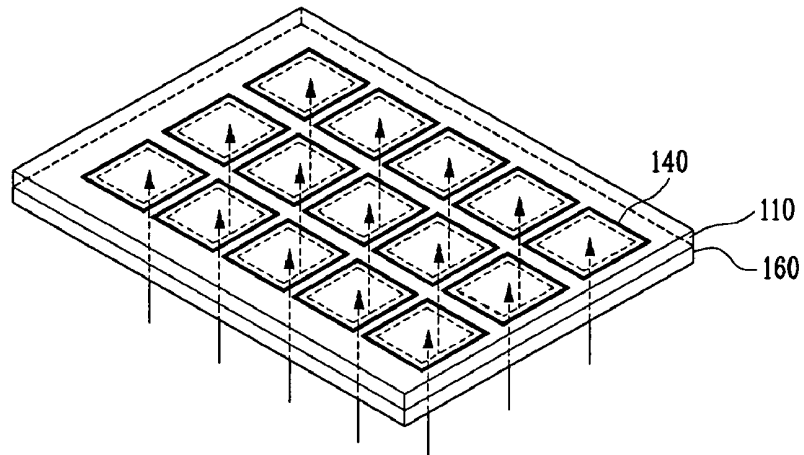

FIG. 2D

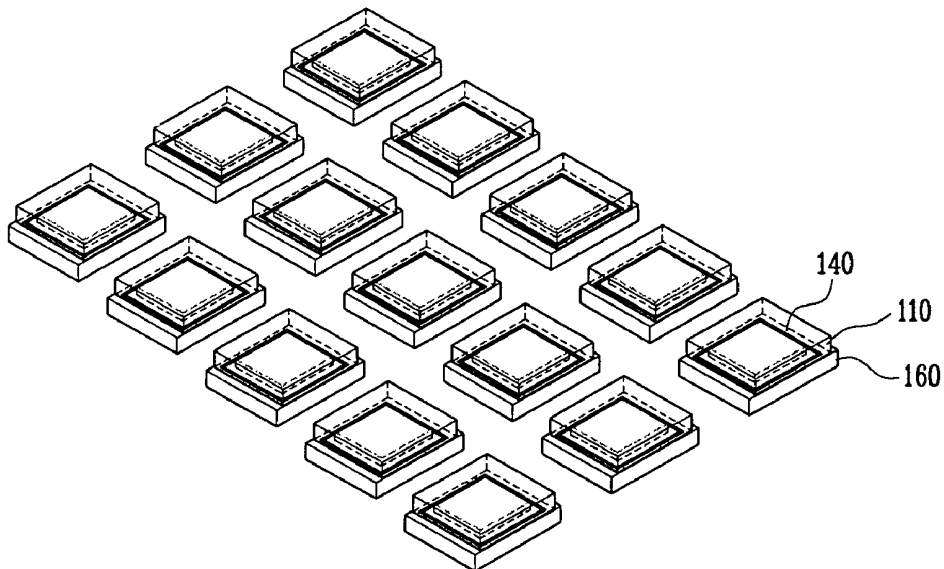

FIG. 2E

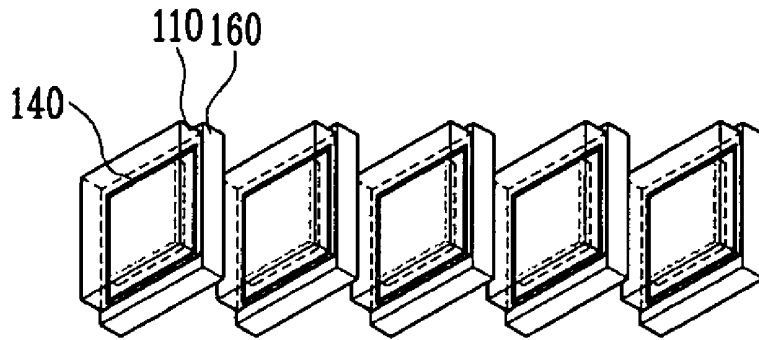

FIG. 2F

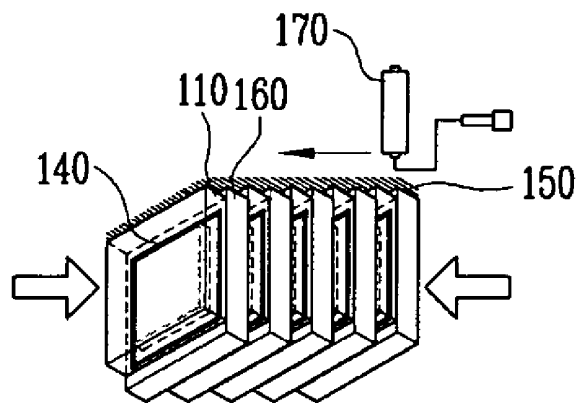

FIG. 3A

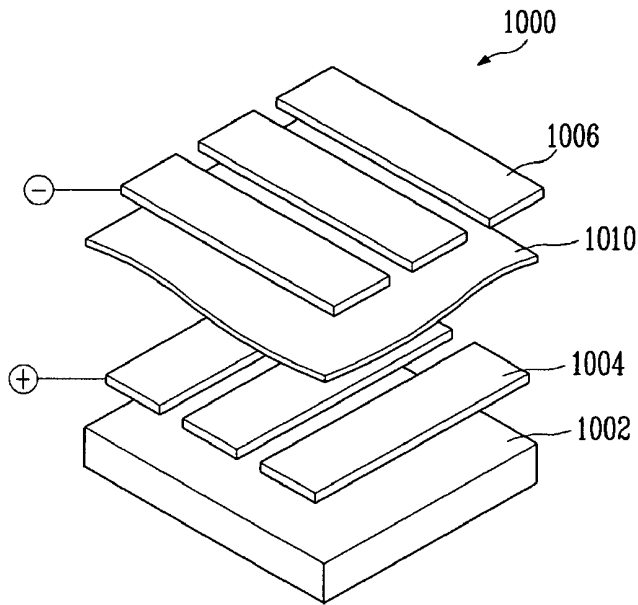

FIG. 3B

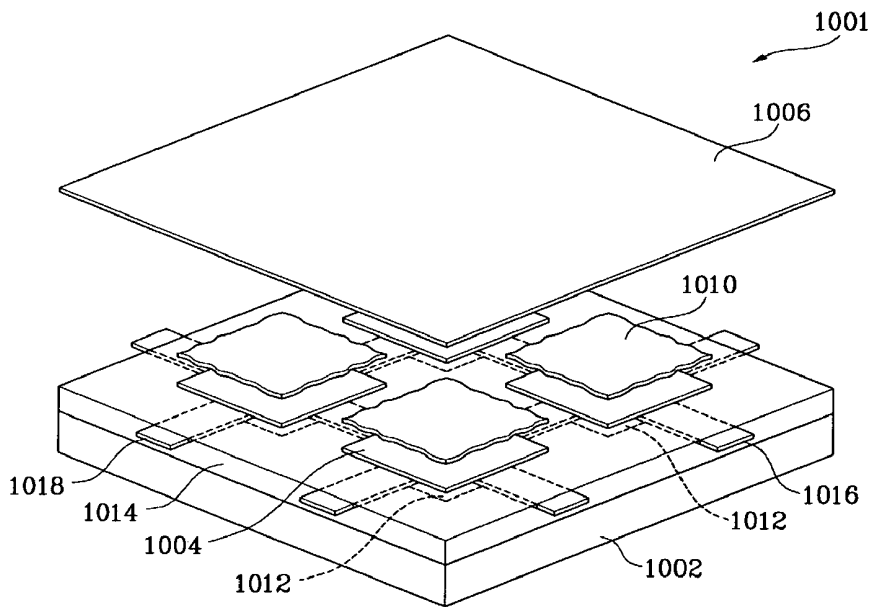

FIG. 3C

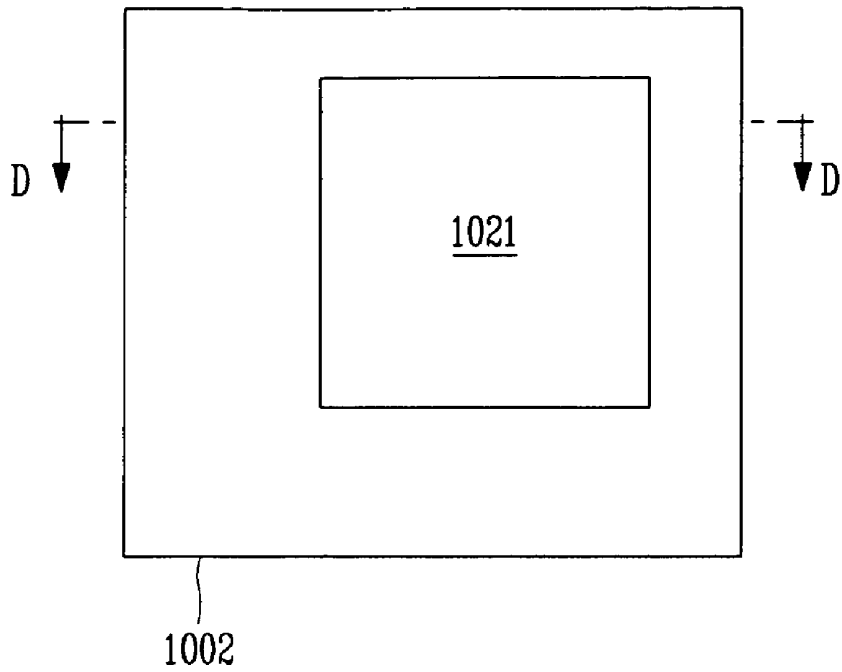

FIG. 3D

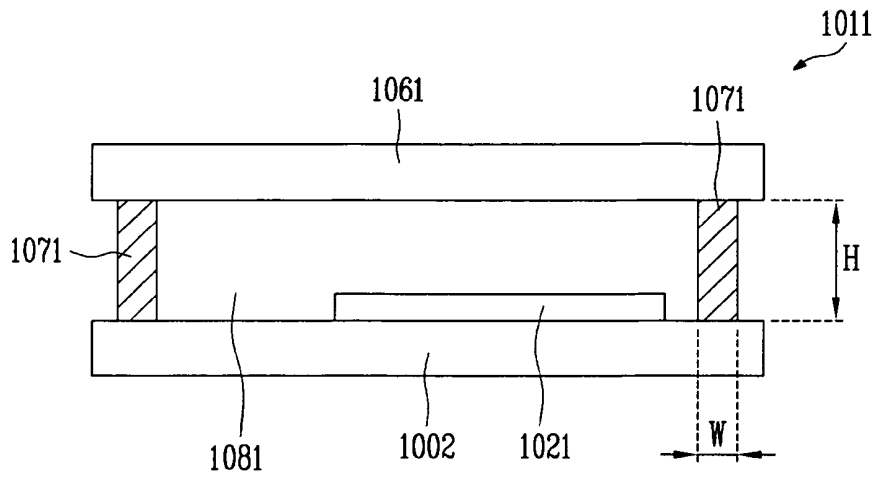
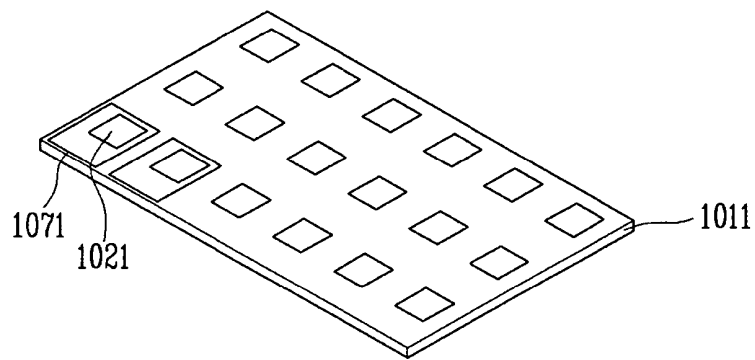

FIG. 3E



**METHOD FOR PACKAGING ORGANIC
LIGHT EMITTING DISPLAY WITH FRIT
SEAL AND REINFORCING STRUCTURE**

CROSS-REFERENCE TO RELATED
APPLICATIONS

This application claims the benefit of Korean Patent Appli-
cation No. 10-2006-0016856, filed on Feb. 21, 2006, in the
Korean Intellectual Property Office, the disclosure of which is
incorporated herein by reference in its entirety. This applica-
tion is related to and incorporates herein by reference the
entire contents of the following concurrently filed applica-
tions:

Title	Filing Date	Application No.
ORGANIC LIGHT-EMITTING DISPLAY DEVICE AND METHOD OF FABRICATING THE SAME	Sep. 29, 2006	11/541,055
ORGANIC LIGHT-EMITTING DISPLAY DEVICE AND METHOD OF MANUFACTURING THE SAME	Sep. 29, 2006	11/529914
ORGANIC LIGHT EMITTING DISPLAY DEVICE	Sep. 29, 2006	11/541139
ORGANIC LIGHT-EMITTING DISPLAY DEVICE WITH FRIT SEAL AND REINFORCING STRUCTURE	Sep. 29, 2006	11/541047
ORGANIC LIGHT EMITTING DISPLAY DEVICE METHOD OF FABRICATING THE SAME	Sep. 29, 2006	11/540150
ORGANIC LIGHT EMITTING DISPLAY AND METHOD OF FABRICATING THE SAME	Sep. 29, 2006	11/541009
ORGANIC LIGHT-EMITTING DISPLAY DEVICE WITH FRIT SEAL AND REINFORCING STRUCTURE BONDED TO FRAME	Sep. 29, 2006	11/540151
METHOD FOR PACKAGING ORGANIC LIGHT EMITTING DISPLAY WITH FRIT SEAL AND REINFORCING STURUTURE	Sep. 29, 2006	11/529910
ORGANIC LIGHT-EMITTING DISPLAY DEVICE AND THE PREPARATION METHOD OF THE SAME	Sep. 29, 2006	11/540008
ORGANIC LIGHT EMITTING DISPLAY AND FABRICATING METHOD OF THE SAME	Sep. 29, 2006	11/541048
ORGANIC LIGHT-EMITTING DISPLAY AND METHOD OF MAKING THE SAME	Sep. 29, 2006	11/541021
ORGANIC LIGHT EMITTING DISPLAY AND FABRICATING METHOD OF THE SAME	Sep. 29, 2006	11/540024
ORGANIC LIGHT EMITTING DISPLAY DEVICE AND MANUFACTURING METHOD THEREOF	Sep. 29, 2006	11/529995
ORGANIC LIGHT-EMITTING DISPLAY DEVICE AND MANUFACTURING METHOD OF THE SAME	Sep. 29, 2006	11/540157
ORGANIC LIGHT EMITTING DISPLAY AND FABRICATING METHOD OF THE SAME	Sep. 29, 2006	11/540149
ORGANIC LIGHT EMITTING DISPLAY AND METHOD OF FABRICATING THE SAME	Sep. 29, 2006	11/529916
ORGANIC LIGHT EMITTING DISPLAY DEVICE METHOD OF FABRICATING THE SAME	Sep. 29, 2006	11/529891
ORGANIC LIGHT EMITTING DISPLAY AND METHOD OF FABRICATING THE SAME	Sep. 29, 2006	11/540103

BACKGROUND

1. Field of the Invention

The present invention relates to organic light emitting dis-
play devices, and more particularly for packaging of the
device.

2. Discussion of Related Art

In recent years, organic light emitting displays have been
widely used and are relatively simple. The organic light emit-
ting display is referred to as an organic light emitting device,
and is an emissive device using an organic layer as an emis-
sion layer. Since the organic light emitting display can elimi-
nate need for a back light as required in a liquid crystal
display, it can be made thin and light weight. Thus, the
organic light emitting display has been actively developed as
a display panel in a portable information terminal such as
mobile computer, portable telephone, portable game device,
and electronic book.

In general, the organic light emitting display has a structure
in which at least one organic layer having an emission layer is
interposed between a pair of electrodes, namely, a first elec-
trode and a second electrode. The first electrode is formed on
a substrate, and functions as an anode to inject holes. An
organic layer is formed at an upper portion of the first elec-
trode. The second electrode is formed on the organic layer to
face the first electrode, and functions as a cathode to inject
electrons.

When moisture or oxygen from ambient environment is
introduced in a device, the life of such an organic light emit-
ting display is reduced, emission efficiency is deteriorated,
and emission color changes due to oxidation and peeling.

Therefore, in manufacturing the organic light emitting dis-
play, it is well known that the device is separate and sealed
from an outside to prevent moisture from infiltrating into it. In
the sealing method, after organic macromolecule such as
polyester (PET) is laminated at an upper portion of the
organic light emitting display, or a cover or a cap is formed by
a glass or a metal having absorbent, the inside thereof is filled
with nitrogen gas. Then, edges of the cover or the cap are
capsule-sealed by a sealant such as epoxy.

However, it is impossible for the conventional method to
prevent the introduction of device destructive factors such as
moisture or oxygen from an outside by 100%. Consequently,
a structure of the device is disadvantageous to be applied to an
active surface emitting type organic light emitting display
weak to moisture, and a process to embody such a method is
complicated. In order to solve the aforementioned problems,
a capsule sealing method is devised to enhance an adhesion
between a device substrate and a cap using a frit as a sealant.
U.S. Pat. No. 6,998,776 B2 discloses a structure of sealing an
organic light emitting display by coating a frit at a glass
substrate.

SUMMARY OF CERTAIN INVENTIVE ASPECTS

An aspect of the invention provides a method for making an
organic light emitting display device, which may comprise:
providing first and second devices, each device comprising: a
first substrate comprising a first side surface, a second sub-
strate comprising a first side surface and opposing the first
substrate, an array of organic light emitting pixels interposed
between the first and second substrates, a frit seal interposed
between the first substrate and the second substrate while
surrounding the array, wherein the frit seal, the first substrate
and the second substrate together define an enclosed space in
which the array is located, the frit seal comprising a first side
surface, and a first side comprising the first side surfaces of

the first substrate, second substrates and the frit seal; arranging the first and second devices such that the first substrate of the first device opposing the first or second substrate of the second device and that the first sides of the first and second devices face substantially the same direction; applying a material onto the first sides of the first and second devices, the material being configured to form a reinforcing structure when cured; and curing the material so as to form a reinforcing structure comprising a first portion contacting the first side of the first device and a second portion contacting the first side of the second device.

In the foregoing method, arranging may comprise providing a holder configured to hold the first and second devices, and holding the first and second devices such that the first substrate of the first device opposing the first or second substrate of the second device and that the first sides of the first and second devices face substantially the same direction. Applying the material may comprise causing a medium retaining the material to contact the first sides of the first and second devices. Applying may comprise sliding the medium on the first sides of the first and second devices. The material may be applied while holding the first and second devices together. The medium may comprise a brush. The medium may be arranged with a roll comprising a rotatable cylinder, and wherein applying may comprise rolling the roll over the first sides of the first and second devices while contacting at least part of the first sides.

Still in the foregoing method, the first substrate, the second substrate and the frit seal in combination may form a gap space outside the enclosed space in each of the first and second devices, and wherein at least part of the material may enter into the gap space. Applying the material may comprise causing the material to enter into the gap space. At least part of the material entering into the gap space may spontaneously move toward the frit seal. The gap space may have a depth from the first side surface of the first substrate to the first side surface of the frit seal, and wherein the depth may be from about 0.3 mm to about 0.7 mm. The distance between the first and second substrates in the gap space may be from about 2 μm to about 30 μm .

In the foregoing method, applying the material may comprise causing the material to contact at least part of the first side of the first device and at least part of the first side of the second device. Applying the material may comprise causing the material to contact the first side surface of the frit seal in each of the first and second device. The material may have a viscosity less than about 200 cp. Arranging may comprise placing an insert between the first substrate of the first device and the first or second substrate of the second device. Arranging may comprise contacting the first substrate of the first device with the first or second substrate of the second device.

Still in the foregoing method, the first substrate of the first device is arranged substantially parallel to the first or second substrate of the second device. The first side surface of the frit seal may be substantially parallel to the first side surface of the first substrate. The first portion may contact the frit seal of the first device. The first portion may contact at least one of the first and second substrates. The first and second portions are integrated after curing. The method may further comprise separating the first portion from the second portion. Each of the first and second devices comprises a second side comprising second side surfaces of the first substrate, the second substrate and the frit seal, wherein the method may further comprise applying the material with the second sides of the first and second devices. The medium may move in a direction when applying the material, and wherein an angle between one of the substrates of the first and second devices

and the direction of the movement may be about 5 to 90 degrees when forming the mass of the material. The medium may move in a direction when applying the material, and wherein an angle between one of the substrates of the first and second devices and the direction of the movement may be about 10 to about 89 degrees when forming the mass of the material.

The foregoing method may further comprising providing at least one additional device comprising a first substrate comprising a first side surface, a second substrate comprising a first side surface and opposing the first substrate, an array of organic light emitting pixels interposed between the first and second substrates, a frit seal interposed between the first substrate and the second substrate while surrounding the array, wherein the frit seal, the first substrate and the second substrate may together define an enclosed space in which the array is located, the frit seal comprising a first side surface, and a first side comprising the first side surfaces of the first substrate, the second substrates and the frit seal, wherein arranging may further arrange the at least one additional device together with the first and second devices, wherein applying may further apply the material on the at least one additional device, and wherein curing may form at least one additional structure, each of which contacts the first side of each of the at least one additional device. The frit seal may comprise one or more materials selected from the group consisting of magnesium oxide (MgO), calcium oxide (CaO), barium oxide (BaO), lithium oxide (Li₂O), sodium oxide (Na₂O), potassium oxide (K₂O), boron oxide (B₂O₃), vanadium oxide (V₂O₅), zinc oxide (ZnO), tellurium oxide (TeO₂), aluminum oxide (Al₂O₃), silicon dioxide (SiO₂), lead oxide (PbO), tin oxide (SnO), phosphorous oxide (P₂O₅), ruthenium oxide (Ru₂O), rubidium oxide (Rb₂O), rhodium oxide (Rh₂O), ferrite oxide (Fe₂O₃), copper oxide (CuO), titanium oxide (TiO₂), tungsten oxide (WO₃), bismuth oxide (Bi₂O₃), antimony oxide (Sb₂O₃), lead-borate glass, tin-phosphate glass, vanadate glass, and borosilicate.

Another aspect of the present invention provides a method for manufacturing an organic light emitting display, which fill a reinforcing member at once in a liquid phase between a first substrate and a second substrate by dipping non-pixel regions of unit display panels in the reinforcing member.

Still another aspect of the present invention provides a method for manufacturing an organic light emitting display, comprising the steps of: (i) forming an organic light emitting device at a plurality of pixel regions of a first mother substrate, the first mother substrate including the plurality of pixel regions and a plurality of non-pixel regions; (ii) forming a frit at a second mother substrate corresponding to the non-pixel regions of the first mother substrate; (iii) coalescing the second mother substrate to the first mother substrate so that the plurality of pixel regions of the first mother substrate are sealed by the frit; (iv) cutting the first and second mother substrates coalesced to separate the first and second mother substrates from unit display panels; (v) aligning the unit display panels; and (vi) coating a reinforcing member at an outer side surface of each of the unit display panels. The reinforcing member is formed by a roll printing method. Preferably, the method further comprises a step of curing the reinforcing member after coating the reinforcing member. The reinforcing member is cured by ultra-violet ray, natural curing, or thermal process.

BRIEF DESCRIPTION OF THE DRAWINGS

These and other aspects and advantages of the invention will become apparent and more readily appreciated from the

following description of the embodiments, taken in conjunction with the accompanying drawings of which:

FIG. 1a to FIG. 1f are cross-sectional views showing a method for manufacturing an organic light emitting display according to an embodiment of the present invention, and FIG. 1G is a schematic side view of a plurality of organic light emitting display devices with inserts interposed between the plurality of organic light emitting display devices;

FIG. 2a to FIG. 2f are perspective views showing a method for manufacturing an organic light emitting display according to an embodiment of the present invention;

FIG. 3A is a schematic exploded view of a passive matrix type organic light emitting display device in accordance with one embodiment;

FIG. 3B is a schematic exploded view of an active matrix type organic light emitting display device in accordance with one embodiment;

FIG. 3C is a schematic top plan view of an organic light emitting display in accordance with one embodiment;

FIG. 3D is a cross-sectional view of the organic light emitting display of FIG. 3C, taken along the line d-d; and

FIG. 3E is a schematic perspective view illustrating mass production of organic light emitting devices in accordance with one embodiment.

DETAILED DESCRIPTION OF EMBODIMENTS

Hereinafter, embodiments according to the present invention will be described with reference to the accompanying drawings.

An organic light emitting display (OLED) is a display device comprising an array of organic light emitting diodes. Organic light emitting diodes are solid state devices which include an organic material and are adapted to generate and emit light when appropriate electrical potentials are applied.

OLEDs can be generally grouped into two basic types dependent on the arrangement with which the stimulating electrical current is provided. FIG. 3A schematically illustrates an exploded view of a simplified structure of a passive matrix type OLED 1000. FIG. 3B schematically illustrates a simplified structure of an active matrix type OLED 1001. In both configurations, the OLED 1000, 1001 includes OLED pixels built over a substrate 1002, and the OLED pixels include an anode 1004, a cathode 1006 and an organic layer 1010. When an appropriate electrical current is applied to the anode 1004, electric current flows through the pixels and visible light is emitted from the organic layer.

Referring to FIG. 3A, the passive matrix OLED (PMOLED) design includes elongate strips of anode 1004 arranged generally perpendicular to elongate strips of cathode 1006 with organic layers interposed therebetween. The intersections of the strips of cathode 1006 and anode 1004 define individual OLED pixels where light is generated and emitted upon appropriate excitation of the corresponding strips of anode 1004 and cathode 1006. PMOLEDs provide the advantage of relatively simple fabrication.

Referring to FIG. 3B, the active matrix OLED (AMOLED) includes local driving circuits 1012 arranged between the substrate 1002 and an array of OLED pixels. An individual pixel of AMOLEDs is defined between the common cathode 1006 and an anode 1004, which is electrically isolated from other anodes. Each driving circuit 1012 is coupled with an anode 1004 of the OLED pixels and further coupled with a data line 1016 and a scan line 1018. In embodiments, the scan lines 1018 supply scan signals that select rows of the driving circuits, and the data lines 1016 supply data signals for particular driving circuits. The data signals and scan signals stimulate

the local driving circuits 1012, which excite the anodes 1004 so as to emit light from their corresponding pixels.

In the illustrated AMOLED, the local driving circuits 1012, the data lines 1016 and scan lines 1018 are buried in a planarization layer 1014, which is interposed between the pixel array and the substrate 1002. The planarization layer 1014 provides a planar top surface on which the organic light emitting pixel array is formed. The planarization layer 1014 may be formed of organic or inorganic materials, and formed of two or more layers although shown as a single layer. The local driving circuits 1012 are typically formed with thin film transistors (TFT) and arranged in a grid or array under the OLED pixel array. The local driving circuits 1012 may be at least partly made of organic materials, including organic TFT. AMOLEDs have the advantage of fast response time improving their desirability for use in displaying data signals. Also, AMOLEDs have the advantages of consuming less power than passive matrix OLEDs.

Referring to common features of the PMOLED and AMOLED designs, the substrate 1002 provides structural support for the OLED pixels and circuits. In various embodiments, the substrate 1002 can comprise rigid or flexible materials as well as opaque or transparent materials, such as plastic, glass, and/or foil. As noted above, each OLED pixel or diode is formed with the anode 1004, cathode 1006 and organic layer 1010 interposed therebetween. When an appropriate electrical current is applied to the anode 1004, the cathode 1006 injects electrons and the anode 1004 injects holes. In certain embodiments, the anode 1004 and cathode 1006 are inverted; i.e., the cathode is formed on the substrate 1002 and the anode is oppositely arranged.

Interposed between the cathode 1006 and anode 1004 are one or more organic layers. More specifically, at least one emissive or light emitting layer is interposed between the cathode 1006 and anode 1004. The light emitting layer may comprise one or more light emitting organic compounds. Typically, the light emitting layer is configured to emit visible light in a single color such as blue, green, red or white. In the illustrated embodiment, one organic layer 1010 is formed between the cathode 1006 and anode 1004 and acts as a light emitting layer. Additional layers, which can be formed between the anode 1004 and cathode 1006, can include a hole transporting layer, a hole injection layer, an electron transporting layer and an electron injection layer.

Hole transporting and/or injection layers can be interposed between the light emitting layer 1010 and the anode 1004. Electron transporting and/or injecting layers can be interposed between the cathode 1006 and the light emitting layer 1010. The electron injection layer facilitates injection of electrons from the cathode 1006 toward the light emitting layer 1010 by reducing the work function for injecting electrons from the cathode 1006. Similarly, the hole injection layer facilitates injection of holes from the anode 1004 toward the light emitting layer 1010. The hole and electron transporting layers facilitate movement of the carriers injected from the respective electrodes toward the light emitting layer.

In some embodiments, a single layer may serve both electron injection and transportation functions or both hole injection and transportation functions. In some embodiments, one or more of these layers are lacking. In some embodiments, one or more organic layers are doped with one or more materials that help injection and/or transportation of the carriers. In embodiments where only one organic layer is formed between the cathode and anode, the organic layer may include not only an organic light emitting compound but also certain functional materials that help injection or transportation of carriers within that layer.

There are numerous organic materials that have been developed for use in these layers including the light emitting layer. Also, numerous other organic materials for use in these layers are being developed. In some embodiments, these organic materials may be macromolecules including oligomers and polymers. In some embodiments, the organic materials for these layers may be relatively small molecules. The skilled artisan will be able to select appropriate materials for each of these layers in view of the desired functions of the individual layers and the materials for the neighboring layers in particular designs.

In operation, an electrical circuit provides appropriate potential between the cathode **1006** and anode **1004**. This results in an electrical current flowing from the anode **1004** to the cathode **1006** via the interposed organic layer(s). In one embodiment, the cathode **1006** provides electrons to the adjacent organic layer **1010**. The anode **1004** injects holes to the organic layer **1010**. The holes and electrons recombine in the organic layer **1010** and generate energy particles called "excitons." The excitons transfer their energy to the organic light emitting material in the organic layer **1010**, and the energy is used to emit visible light from the organic light emitting material. The spectral characteristics of light generated and emitted by the OLED **1000**, **1001** depend on the nature and composition of organic molecules in the organic layer(s). The composition of the one or more organic layers can be selected to suit the needs of a particular application by one of ordinary skill in the art.

OLED devices can also be categorized based on the direction of the light emission. In one type referred to as "top emission" type, OLED devices emit light and display images through the cathode or top electrode **1006**. In these embodiments, the cathode **1006** is made of a material transparent or at least partially transparent with respect to visible light. In certain embodiments, to avoid losing any light that can pass through the anode or bottom electrode **1004**, the anode may be made of a material substantially reflective of the visible light. A second type of OLED devices emits light through the anode or bottom electrode **1004** and is called "bottom emission" type. In the bottom emission type OLED devices, the anode **1004** is made of a material which is at least partially transparent with respect to visible light. Often, in bottom emission type OLED devices, the cathode **1006** is made of a material substantially reflective of the visible light. A third type of OLED devices emits light in two directions, e.g. through both anode **1004** and cathode **1006**. Depending upon the direction(s) of the light emission, the substrate may be formed of a material which is transparent, opaque or reflective of visible light.

In many embodiments, an OLED pixel array **1021** comprising a plurality of organic light emitting pixels is arranged over a substrate **1002** as shown in FIG. 3C. In embodiments, the pixels in the array **1021** are controlled to be turned on and off by a driving circuit (not shown), and the plurality of the pixels as a whole displays information or image on the array **1021**. In certain embodiments, the OLED pixel array **1021** is arranged with respect to other components, such as drive and control electronics to define a display region and a non-display region. In these embodiments, the display region refers to the area of the substrate **1002** where OLED pixel array **1021** is formed. The non-display region refers to the remaining areas of the substrate **1002**. In embodiments, the non-display region can contain logic and/or power supply circuitry. It will be understood that there will be at least portions of control/drive circuit elements arranged within the display region. For example, in PMOLEDs, conductive components will extend into the display region to provide appropriate

potential to the anode and cathodes. In AMOLEDs, local driving circuits and data/scan lines coupled with the driving circuits will extend into the display region to drive and control the individual pixels of the AMOLEDs.

One design and fabrication consideration in OLED devices is that certain organic material layers of OLED devices can suffer damage or accelerated deterioration from exposure to water, oxygen or other harmful gases. Accordingly, it is generally understood that OLED devices be sealed or encapsulated to inhibit exposure to moisture and oxygen or other harmful gases found in a manufacturing or operational environment. FIG. 3D schematically illustrates a cross-section of an encapsulated OLED device **1011** having a layout of FIG. 3C and taken along the line d-d of FIG. 3C. In this embodiment, a generally planar top plate or substrate **1061** engages with a seal **1071** which further engages with a bottom plate or substrate **1002** to enclose or encapsulate the OLED pixel array **1021**. In other embodiments, one or more layers are formed on the top plate **1061** or bottom plate **1002**, and the seal **1071** is coupled with the bottom or top substrate **1002**, **1061** via such a layer. In the illustrated embodiment, the seal **1071** extends along the periphery of the OLED pixel array **1021** or the bottom or top plate **1002**, **1061**.

In embodiments, the seal **1071** is made of a frit material as will be further discussed below. In various embodiments, the top and bottom plates **1061**, **1002** comprise materials such as plastics, glass and/or metal foils which can provide a barrier to passage of oxygen and/or water to thereby protect the OLED pixel array **1021** from exposure to these substances. In embodiments, at least one of the top plate **1061** and the bottom plate **1002** are formed of a substantially transparent material.

To lengthen the life time of OLED devices **1011**, it is generally desired that seal **1071** and the top and bottom plates **1061**, **1002** provide a substantially non-permeable seal to oxygen and water vapor and provide a substantially hermetically enclosed space **1081**. In certain applications, it is indicated that the seal **1071** of a frit material in combination with the top and bottom plates **1061**, **1002** provide a barrier to oxygen of less than approximately 10^{-3} cc/m²-day and to water of less than 10^{-6} g/m²-day. Given that some oxygen and moisture can permeate into the enclosed space **1081**, in some embodiments, a material that can take up oxygen and/or moisture is formed within the enclosed space **1081**.

The seal **1071** has a width W, which is its thickness in a direction parallel to a surface of the top or bottom substrate **1061**, **1002** as shown in FIG. 3D. The width varies among embodiments and ranges from about 300 μ m to about 3000 μ m, optionally from about 500 μ m to about 1500 μ m. Also, the width may vary at different positions of the seal **1071**. In some embodiments, the width of the seal **1071** may be the largest where the seal **1071** contacts one of the bottom and top substrate **1002**, **1061** or a layer formed thereon. The width may be the smallest where the seal **1071** contacts the other. The width variation in a single cross-section of the seal **1071** relates to the cross-sectional shape of the seal **1071** and other design parameters.

The seal **1071** has a height H, which is its thickness in a direction perpendicular to a surface of the top or bottom substrate **1061**, **1002** as shown in FIG. 3D. The height varies among embodiments and ranges from about 2 μ m to about 30 μ m, optionally from about 10 μ m to about 15 μ m. Generally, the height does not significantly vary at different positions of the seal **1071**. However, in certain embodiments, the height of the seal **1071** may vary at different positions thereof.

In the illustrated embodiment, the seal **1071** has a generally rectangular cross-section. In other embodiments, however,

the seal **1071** can have other various cross-sectional shapes such as a generally square cross-section, a generally trapezoidal cross-section, a cross-section with one or more rounded edges, or other configuration as indicated by the needs of a given application. To improve hermeticity, it is generally desired to increase the interfacial area where the seal **1071** directly contacts the bottom or top substrate **1002**, **1061** or a layer formed thereon. In some embodiments, the shape of the seal can be designed such that the interfacial area can be increased.

The seal **1071** can be arranged immediately adjacent the OLED array **1021**, and in other embodiments, the seal **1071** is spaced some distance from the OLED array **1021**. In certain embodiments, the seal **1071** comprises generally linear segments that are connected together to surround the OLED array **1021**. Such linear segments of the seal **1071** can extend, in certain embodiments, generally parallel to respective boundaries of the OLED array **1021**. In other embodiment, one or more of the linear segments of the seal **1071** are arranged in a non-parallel relationship with respective boundaries of the OLED array **1021**. In yet other embodiments, at least part of the seal **1071** extends between the top plate **1061** and bottom plate **1002** in a curvilinear manner.

As noted above, in certain embodiments, the seal **1071** is formed using a frit material or simply "frit" or glass frit," which includes fine glass particles. The frit particles includes one or more of magnesium oxide (MgO), calcium oxide (CaO), barium oxide (BaO), lithium oxide (Li₂O), sodium oxide (Na₂O), potassium oxide (K₂O), boron oxide (B₂O₃), vanadium oxide (V₂O₅), zinc oxide (ZnO), tellurium oxide (TeO₂), aluminum oxide (Al₂O₃), silicon dioxide (SiO₂), lead oxide (PbO), tin oxide (SnO), phosphorous oxide (P₂O₅), ruthenium oxide (Ru₂O), rubidium oxide (Rb₂O), rhodium oxide (Rh₂O), ferrite oxide (Fe₂O₃), copper oxide (CuO), titanium oxide (TiO₂), tungsten oxide (WO₃), bismuth oxide (Bi₂O₃), antimony oxide (Sb₂O₃), lead-borate glass, tin-phosphate glass, vanadate glass, and borosilicate, etc. In embodiments, these particles range in size from about 2 μm to about 30 μm, optionally about 5 μm to about 10 μm, although not limited only thereto. The particles can be as large as about the distance between the top and bottom substrates **1061**, **1002** or any layers formed on these substrates where the frit seal **1071** contacts.

The frit material used to form the seal **1071** can also include one or more filler or additive materials. The filler or additive materials can be provided to adjust an overall thermal expansion characteristic of the seal **1071** and/or to adjust the absorption characteristics of the seal **1071** for selected frequencies of incident radiant energy. The filler or additive material(s) can also include inversion and/or additive fillers to adjust a coefficient of thermal expansion of the frit. For example, the filler or additive materials can include transition metals, such as chromium (Cr), iron (Fe), manganese (Mn), cobalt (Co), copper (Cu), and/or vanadium. Additional materials for the filler or additives include ZnSiO₄, PbTiO₃, ZrO₂, eucryptite.

In embodiments, a frit material as a dry composition contains glass particles from about 20 to 90 about wt %, and the remaining includes fillers and/or additives. In some embodiments, the frit paste contains about 10-30 wt % organic materials and about 70-90% inorganic materials. In some embodiments, the frit paste contains about 20 wt % organic materials and about 80 wt % inorganic materials. In some embodiments, the organic materials may include about 0-30 wt % binder(s) and about 70-100 wt % solvent(s). In some embodiments, about 10 wt % is binder(s) and about 90 wt % is solvent(s) among the organic materials. In some embodi-

ments, the inorganic materials may include about 0-10 wt % additives, about 20-40 wt % fillers and about 50-80 wt % glass powder. In some embodiments, about 0-5 wt % is additive(s), about 25-30 wt % is filler(s) and about 65-75 wt % is the glass powder among the inorganic materials.

In forming a frit seal, a liquid material is added to the dry frit material to form a frit paste. Any organic or inorganic solvent with or without additives can be used as the liquid material. In embodiments, the solvent includes one or more organic compounds. For example, applicable organic compounds are ethyl cellulose, nitro cellulose, hydroxyl propyl cellulose, butyl carbitol acetate, terpineol, butyl cellusolve, acrylate compounds. Then, the thus formed frit paste can be applied to form a shape of the seal **1071** on the top and/or bottom plate **1061**, **1002**.

In one exemplary embodiment, a shape of the seal **1071** is initially formed from the frit paste and interposed between the top plate **1061** and the bottom plate **1002**. The seal **1071** can in certain embodiments be pre-cured or pre-sintered to one of the top plate and bottom plate **1061**, **1002**. Following assembly of the top plate **1061** and the bottom plate **1002** with the seal **1071** interposed therebetween, portions of the seal **1071** are selectively heated such that the frit material forming the seal **1071** at least partially melts. The seal **1071** is then allowed to resolidify to form a secure joint between the top plate **1061** and the bottom plate **1002** to thereby inhibit exposure of the enclosed OLED pixel array **1021** to oxygen or water.

In embodiments, the selective heating of the frit seal is carried out by irradiation of light, such as a laser or directed infrared lamp. As previously noted, the frit material forming the seal **1071** can be combined with one or more additives or filler such as species selected for improved absorption of the irradiated light to facilitate heating and melting of the frit material to form the seal **1071**.

In some embodiments, OLED devices **1011** are mass produced. In an embodiment illustrated in FIG. 3E, a plurality of separate OLED arrays **1021** is formed on a common bottom substrate **1101**. In the illustrated embodiment, each OLED array **1021** is surrounded by a shaped frit to form the seal **1071**. In embodiments, common top substrate (not shown) is placed over the common bottom substrate **1101** and the structures formed thereon such that the OLED arrays **1021** and the shaped frit paste are interposed between the common bottom substrate **1101** and the common top substrate. The OLED arrays **1021** are encapsulated and sealed, such as via the previously described enclosure process for a single OLED display device. The resulting product includes a plurality of OLED devices kept together by the common bottom and top substrates. Then, the resulting product is cut into a plurality of pieces, each of which constitutes an OLED device **1011** of FIG. 3D. In certain embodiments, the individual OLED devices **1011** then further undergo additional packaging operations to further improve the sealing formed by the frit seal **1071** and the top and bottom substrates **1061**, **1002**.

Occasionally, the sealing material may not completely prevent moisture or air entering into the enclosed space. Also, there may be cracks in the sealing material and in the interfacial area where the sealing material contacts the substrate for various reasons.

FIG. 1a to FIG. 1f are cross-sectional views showing a method for manufacturing an organic light emitting display according to an embodiment of the present invention. FIG. 2a to FIG. 2f are perspective views showing a method for manufacturing an organic light emitting display according to an embodiment of the present invention. FIG. 1a to FIG. 1f and FIG. 2a to FIG. 2f illustrate an embodiment of the present

invention, but the present invention is not limited to the embodiments illustrated in FIG. 1*a* to FIG. 1*f* and FIG. 2*a* to FIG. 2*f*.

Hereinafter, two display panels among a plurality of display panels that are continuously arranged, are referred to as a first display panel **120** and a second display panel **130**, respectively. With reference to FIG. 1*a* and FIG. 2*a*, at least the first display panel **120** and the second display panel **130** are formed at a first mother substrate **110** in such a way that they are arranged in sequence. The first display panel **120** includes a first pixel region **120a** and a first non-pixel region **120b**. The second display panel **130** includes a second pixel region **130a** and a second non-pixel region **130b**. A second mother substrate **160** is positioned at a lower portion of the first mother substrate **110**, and covers the first mother substrate **110**. A cut line (not shown) is formed at each of the first mother substrate **110** and the second mother substrate **120**, which separates respective display panels from each other. For example, a cut line is formed at a boundary between the first pixel region **120b** of the first display panel **120** and the second non-pixel region **130b** of the second display panel **130**.

Referring to FIGS. 1*b* and 2*b*, in one surface of the second mother substrate **160**, a frit **140** is coated at a part corresponding to a peripheral portion of each of the pixel regions **120a** and **130a**, which seals at least the pixel regions **120a** and **130a** of the first mother substrate **110**. That is, the frit **140** is coated along a peripheral region corresponding to the pixel regions **120a** and **130a** formed in the first mother substrate **110**. In an embodiment, the frit **140** includes a filler (not shown) and an absorbent (not shown). The filler adjusts a thermal expansion coefficient of the frit **140**. The absorbent adsorbs laser or infrared ray. The frit **140** is made in a form of a glass powder having an oxide powder. By rapidly reducing a temperature of a heated glass material, the frit **140** is formed in a glass powder pattern. Organic substance is added to the frit **140** to make a paste in a gel state. Then, the frit **140** is sintered at a predetermined temperature to remove the organic substance. The frit paste in a gel state is cured to form the frit seal **140** in a solid state. In an embodiment, preferably, a temperature of sintering the frit **140** ranges from about 300° C. to about 700° C.

With reference to FIG. 1*c* and FIG. 2*c*, after the first mother substrate **110** and the second mother substrate **160** are coalesced to each other, a laser or infrared ray is irradiated to the frit **140**, thereby melting the frit **140**, and then the frit is cured. Accordingly, the first mother substrate **110** and the second mother substrate **160** are coalesced to each other. The second mother substrate **160** covers the first mother substrate **110**, predetermined enclosed space is formed in the device and the organic light emitting pixels are protected from external oxygen or moisture.

Referring to FIG. 1*d* and FIG. 2*d*, a cutting process is performed using a cutting machine, and then the first and second mother substrates **110** and **160** coalesced is divided into respective unit display panels. The cutting process is carried out along a cut line (not shown) formed on the first and second mother substrates **110** and **160**.

With reference to FIG. 1*e* and FIG. 2*e*, the divided unit display panels or unfinished devices are aligned inside an alignment means (not shown). A slot and a partition are provided inside the alignment means to have a structure capable of receiving unit display panels. In an embodiment, the unit display panels are aligned inside the alignment means to be adjacent to each other. A first substrate of a unit display panel which is one of aligned unit display panels and a second substrate in another aligned unit display panel, which is adjacent to the unit display panel, are facing each other and apart

from each other. A reinforcing member **150** is formed in each unit display panel, using alignment means to reduce a process time.

Herein, the alignment means is an auxiliary means to easily coat the reinforcing member **150** to be described later, and the invention is not limited to a specific configuration thereof. Moreover, materials which do not have adhesive strength with the reinforcing member **150** may be used in the alignment means in order to easily separate the unit display panels after coating the reinforcing member.

With reference to FIG. 1*f* and FIG. 2*f*, the unit display panels **120** and **130** aligned in the alignment means are preferably retained in a slot or a partition provided in the alignment means so that the reinforcing material does not flow on a pixel region of a unit display panel during or after the formation process of the reinforcing member **150**.

Next, the reinforcing material is coated at upper portions of the retained unit display panels, and the reinforcing material is formed between the substrates and outside the fit **140** by using a roller **170**. In an embodiment, the reinforcing material can be formed using a roll printing method or a simultaneous printing method. In an embodiment, such reinforcing material is made of resin syrup. Acrylate cyanide, acrylate, epoxy, acrylate and urethane acrylate may be used as the reinforcing member **150**. The acrylate cyanide is a material that is naturally cured. The acrylate is a material that is thermally cured at a temperature less than about 80° C. The epoxy acrylate and urethane acrylate are a material that is cured by ultra-violet ray. In an embodiment, after separating the unit display panels from the alignment means, ultra-violet curing, natural curing, or thermal process for the reinforcing material is performed to form reinforcing member **150**. Referring to FIG. 1*g*, in an embodiment, an insert **180** is interposed between the substrates **110** and **160** of two neighboring devices.

As apparent from the above description, in accordance with the present invention, a reinforcing member is further formed outside the frit adhering first and second substrates to each other. This may prevent an organic light emitting display from easily being broken or damaged due to impact, and improve reliability of the device. Moreover, this may perfectly protect organic light emitting pixels from the ambient environment. Also, after aligning or arranging a plurality of unit display panels, reinforcing members are simultaneously formed. Accordingly, this method can reduce a process time as compared with a method of forming reinforcing members one by one of respective unit display panels, and therefore, the present invention extremely enhances mass productivity of an organic light emitting display.

Although a few embodiments of the present invention have been shown and described, it would be appreciated by those skilled in the art that changes might be made in this embodiment without departing from the principles and spirit of the invention, the scope of which is defined in the claims and their equivalents.

What is claimed is:

1. A method for making an organic light emitting display device, the method comprising:

providing first and second devices, each device comprising:

a first substrate comprising a first side surface and a front surface,

a second substrate comprising a first side surface and a rear surface and opposing the first substrate, wherein the front and rear surfaces face away from each other, an array of organic light emitting pixels interposed between the first and second substrates,

a display surface configured to display an image thereon, wherein the display surface is at least part of at least one of the front and rear surfaces,

a frit seal interposed between the first substrate and the second substrate while surrounding the array, wherein the frit seal, the first substrate and the second substrate together define an enclosed space in which the array is located, the frit seal comprising a first side surface, and

a first side comprising the first side surfaces of the first substrate, second substrates and the frit seal;

arranging the first and second devices such that the front surface of the first device opposes the front or rear surface of the second device and that the first sides of the first and second devices face substantially the same direction;

applying a material onto the first sides of the first and second devices, the material being configured to form a reinforcing structure when cured; and

curing the material so as to form a reinforcing structure comprising a first portion contacting the first side of the first device and a second portion contacting the first side of the second device.

2. The method of claim 1, wherein arranging comprises: holding the first and second devices such that the front surface of the first device opposing the front or rear surface of the second device and that the first sides of the first and second devices face substantially the same direction.

3. The method of claim 1, wherein applying the material while holding the first and second devices together.

4. A method for making an organic light emitting display device, the method comprising:

providing first and second devices, each device comprising:

a first substrate comprising a first side surface,

a second substrate comprising a first side surface and opposing the first substrate,

an array of organic light emitting pixels interposed between the first and second substrates,

a frit seal interposed between the first substrate and the second substrate while surrounding the array, wherein the frit seal, the first substrate and the second substrate together define an enclosed space in which the array is located, the frit seal comprising a first side surface, and

a first side comprising the first side surfaces of the first substrate, second substrates and the frit seal;

arranging the first and second devices such that the first substrate of the first device opposes the first or second substrate of the second device and that the first sides of the first and second devices face substantially the same direction;

applying a material onto the first sides of the first and second devices, the material being configured to form a reinforcing structure when cured; and

curing the material so as to form a reinforcing structure comprising a first portion contacting the first side of the first device and a second portion contacting the first side of the second device,

wherein applying the material comprises causing a medium retaining the material to contact the first sides of the first and second devices.

5. The method of claim 4, wherein applying comprises sliding the medium on the first sides of the first and second devices.

6. The method of claim 4, wherein the medium comprise a brush.

7. The method of claim 4, wherein the medium is arranged with a roll comprising a rotatable cylinder, and wherein applying comprises rolling the roll over the first sides of the first and second devices while contacting at least part of the first sides.

8. The method of claim 1, wherein the first substrate, the second substrate and the frit seal in combination form a gap space outside the enclosed space in each of the first and second devices, and wherein at least part of the material enters into the gap space.

9. The method of claim 8, wherein applying the material comprises causing the material to enter into the gap space.

10. The method of claim 9, wherein at least part of the material entering into the gap space spontaneously moves toward the frit seal.

11. The method of claim 8, wherein the gap space has a depth from the first side surface of the first substrate to the first side surface of the frit seal, and wherein the depth is from about 0.3 mm to about 0.7 mm.

12. The method of claim 8, wherein the distance between the first and second substrates in the gap space is from about 2 μm to about 30 μm .

13. The method of claim 1, wherein applying the material comprises causing the material to contact at least part of the first side of the first device and at least part of the first side of the second device.

14. The method of claim 1, wherein applying the material comprises causing the material to contact the first side surface of the frit seal in each of the first and second device.

15. The method of claim 1, wherein the material has a viscosity less than about 200 cp.

16. The method of claim 1, wherein arranging comprises placing an insert between the first substrate of the first device and the first or second substrate of the second device.

17. The method of claim 1, wherein arranging comprises contacting the first substrate of the first device with the first or second substrate of the second device.

18. The method of claim 1, wherein the first substrate of the first device is arranged substantially parallel to the first or second substrate of the second device.

19. The method of claim 1, wherein the first side surface of the frit seal is substantially parallel to the first side surface of the first substrate.

20. The method of claim 1, wherein the first portion contacts the frit seal of the first device.

21. The method of claim 1, wherein the first portion contacts at least one of the first and second substrates.

22. method of claim 1, wherein the first and second portions are integrated after curing.

23. method of claim 22, further comprising separating the first portion from the second portion.

24. The method of claim 1, wherein each of the first and second devices comprises a second side comprising second side surfaces of the first substrate, the second substrate and the frit seal, wherein the method further comprises applying the material with the second sides of the first and second devices.

25. The method of claim 1, further comprising providing at least one additional device comprising:

a first substrate comprising a first side surface,

a second substrate comprising a first side surface and opposing the first substrate,

an array of organic light emitting pixels interposed between the first and second substrates,

15

a frit seal interposed between the first substrate and the second substrate while surrounding the array, wherein the frit seal, the first substrate and the second substrate together define an enclosed space in which the array is located, the frit seal comprising a first side surface, and a first side comprising the first side surfaces of the first substrate, the second substrates and the frit seal;

wherein arranging further arranges the at least one additional device together with the first and second devices;

wherein applying further applies the material on the at least one additional device; and

wherein curing forms at least one additional structure, each of which contacts the first side of each of the at least one additional device.

16

26. The method of claim 1, wherein the frit seal comprises one or more materials selected from the group consisting of magnesium oxide (MgO), calcium oxide (CaO), barium oxide (BaO), lithium oxide (Li₂O), sodium oxide (Na₂O), potassium oxide (K₂O), boron oxide (B₂O₃), vanadium oxide (V₂O₅), zinc oxide (ZnO), tellurium oxide (TeO₂), aluminum oxide (Al₂O₃), silicon dioxide (SiO₂), lead oxide (PbO), tin oxide (SnO), phosphorous oxide (P₂O₅), ruthenium oxide (Ru₂O), rubidium oxide (Rb₂O), rhodium oxide (Rh₂O), ferrite oxide (Fe₂O₃), copper oxide (CuO), titanium oxide (TiO₂), tungsten oxide (WO₃), bismuth oxide (Bi₂O₃), antimony oxide (Sb₂O₃), lead-borate glass, tin-phosphate glass, vanadate glass, and borosilicate.

* * * * *

专利名称(译)	用于包装玻璃料密封和增强结构的有机发光显示器的方法		
公开(公告)号	US7514280	公开(公告)日	2009-04-07
申请号	US11/540084	申请日	2006-09-29
申请(专利权)人(译)	三星SDI CO. , LTD.		
当前申请(专利权)人(译)	三星DISPLAY CO. , LTD.		
[标]发明人	LEE JAE SUN		
发明人	LEE, JAE SUN		
IPC分类号	H01L51/56 H01L21/782		
CPC分类号	H01L51/5237 H01L25/046 H01L2251/566 H01L51/5246 H01L24/97 H01L51/524 H01L2924/0002 H01L2924/12042 H01L2924/12044 H01L2924/00		
审查员(译)	VU , DAVID		
优先权	1020060016856 2006-02-21 KR		
其他公开文献	US20070196949A1		
外部链接	Espacenet USPTO		

摘要(译)

公开了一种通过在单位显示面板的非像素区域上滚动保持可固化材料的辊而在第一基板和第二基板之间封装有机发光显示器的方法。有机发光像素阵列形成在第一母基板的多个像素区域处。在与第一母基板的非像素区域对应的第二母基板的位置处形成玻璃料。母基板彼此聚结并由玻璃料密封。将第一和第二母基板切割成单元显示板。单元显示面板对齐。可固化材料涂覆在单元显示板的一侧并固化以形成加强构件。

